

Three-point grippers HGDD, sealed

FESTO



Key features

At a glance

General

The fully encapsulated gripper kinematics enable the gripper to be used in extremely harsh ambient conditions.

The sturdy and precise kinematics provide maximum torque resistance and a long service life.

The force generated by the linear motion is translated into the gripper jaw movement via a wedge mechanism with force-guided motion. This also guarantees synchronous movement of the gripper jaws. The virtually backlash-free plain-bearing guide is realised using ground-in gripper jaws.

Note

Engineering software

Gripper selection

→ www.festo.com

Flexible range of applications

- Can be used as a double-acting and single-acting gripper
- Compression spring for supplementing or retaining the gripping forces
- Suitable for external and internal gripping

Wide range of supply ports

Directly from the front

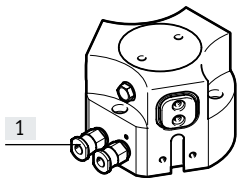

[1] Compressed air supply ports

[2] O-rings

Via adapter plate from underneath

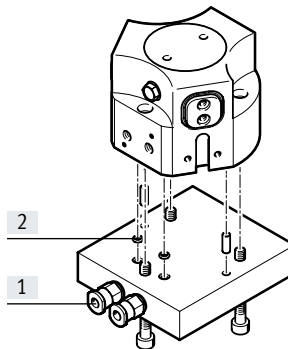

Other connections

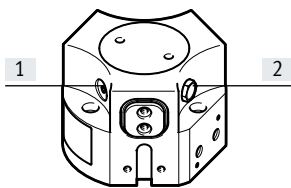

[1] Port for lubrication nipple

[2] Exhaust hole or sealing air connection

Use in harsh ambient conditions

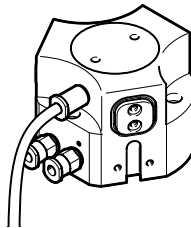

When using the gripper in humid environments or with liquid/gaseous media, make sure that the filter is installed in a neutral environment. The same applies to unused supply ports when operating the gripper as a single-acting gripper.

Key features

Mounting options

Direct mounting
from above

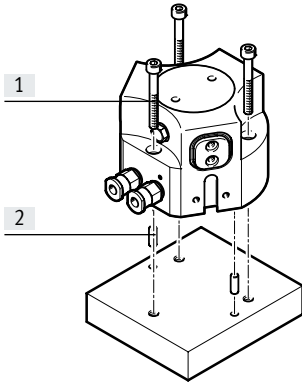

- [1] Mounting screws
- [2] Centring pins

Via adapter plate
from underneath

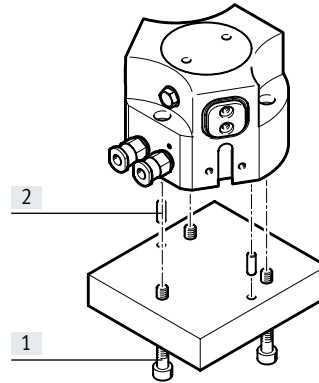

Note

These grippers are not suitable or are of limited suitability for the following application examples:

Not suitable for:

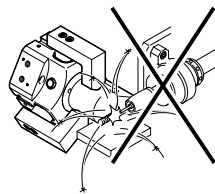

- Welding spatter

Of limited suitability for:

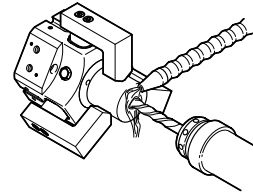

- Aggressive media only possible after consultation with Festo

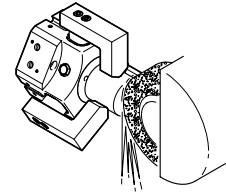

- Grinding dust

Three-point grippers HGDD, sealed

Type codes

001	Series
HGDD	Three-point gripper, sealed

002	Size
35	35
40	40
50	50
63	63
80	80

003	Position sensing
A	For proximity sensor

004	Gripping force backup
	None
G1	Opening
G2	N/O contact

Peripherals overview

Peripherals overview

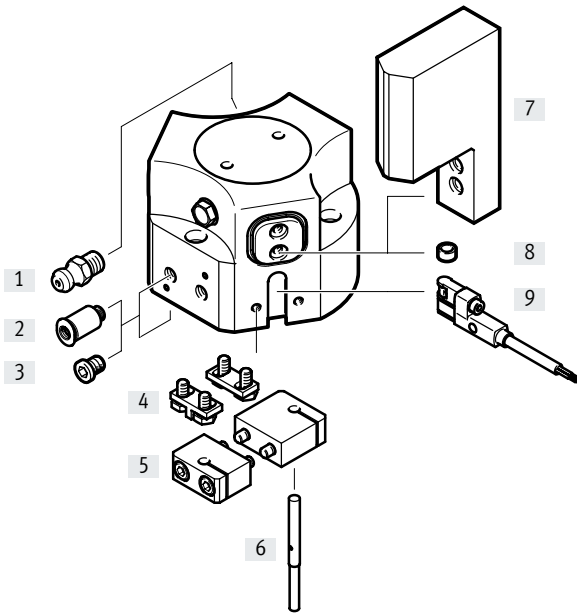

System product for handling and assembly technology

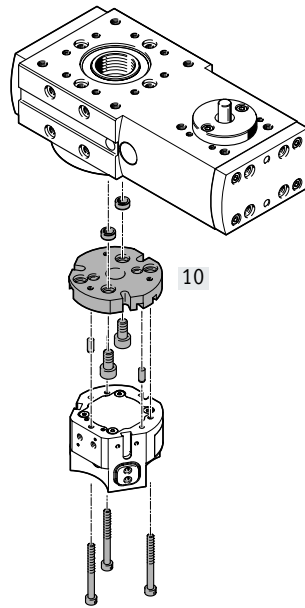

Proportional-pressure regulator VPPM

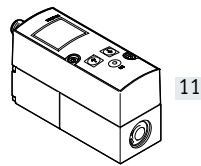

Accessories		
Type	Description	→ Page/Internet
[1] Lubrication nipple	Included in the scope of delivery of the gripper	-
[2] Push-in fitting QS	For connecting tubing with standard O.D.	qs
[3] Blanking plug B	For sealing the compressed air supply ports when using the lower compressed air supply ports	17
[4] Sensor bracket DASI	Switch lug for sensing the gripper jaw position. Mounted on the gripper jaw blank	17
[5] Sensor bracket DASI	Clamping block for securing the proximity sensors SIEH or SIEN	17
[6] Proximity sensor SIEH/SIEN	For sensing the piston position	18
[7] Gripper jaw blank BUB-HGDD	Unmachined part specially matched to the gripper jaws for custom production of gripper fingers	16
[8] Centring sleeve ZBH	<ul style="list-style-type: none"> For centring the gripper jaw blanks/gripper fingers on the gripper jaws 6 centring sleeves included in the scope of delivery of the gripper 	17
[9] Proximity sensor SMT-8G	<ul style="list-style-type: none"> For sensing the piston position, 3 slots available Proximity sensor does not project past the housing at the bottom 	17
[10] Adapter kit DHAA, HAPG	Connecting plate between drive and gripper	14
[11] Proportional-pressure regulator VPPM	For infinite adjustment of the gripping force	vppm

Three-point grippers HGDD, sealed

Data sheet

Function
Double-acting
HGDD-...

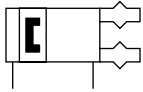

- Size
35 ... 80 mm
- Total stroke
4 ... 12 mm

www.festo.com

Function – Variant
Single-acting or with gripping force retention

opening: HGDD-...-G1



closing: HGDD-...-G2

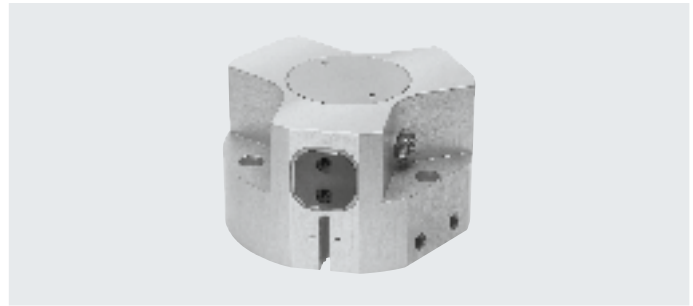

General technical data						
Size	35	40	50	63	80	
Design	Wedge-shaped actuator Force-guided motion					
Mode of operation	Double-acting					
Gripper function	3-point					
Number of gripper jaws	3					
Max. load per gripper finger ¹⁾	[g]	57	130	276	440	790
Stroke per gripper jaw	[mm]	4	6	8	10	12
Pneumatic connection	M5	M5	G1/8	G1/8	G1/8	
Pneumatic connection for sealing air	M3	M3	M5	M5	G1/8	
Pneumatic connection for lubrication nipple	M3	M3	M5	M5	M5	
Repetition accuracy ²⁾	[mm]	≤ 0.03			≤ 0.05	
Max. interchangeability	[mm]	≤ ±0.2				
Max. operating frequency	[Hz]	≤ 4				
Rotational symmetry	[mm]	< Ø 0.2				
Position sensing	Via proximity sensor					
Type of mounting	With through-hole and dowel pin With female thread and dowel pin					
Mounting position	Any					

- 1) Applies to unthrottled operation
- 2) Under constant exposure to operating conditions, end-position drift occurs, concentric to the central shaft, at 100 consecutive strokes

Operating and environmental conditions		
Min. operating pressure		
HGDD-...-A	[bar]	3
HGDD-...-A-G	[bar]	4
Max. operating pressure	[bar]	8
Operating pressure for sealing air	[bar]	0 ... 0.5
Operating medium	Compressed air to ISO 8573-1:2010 [7:4:4]	
Note on the operating/pilot medium	Lubricated operation possible (in which case lubricated operation will always be required)	
Ambient temperature ¹⁾	[°C]	+5 ... +60
Degree of protection	IP65	
Corrosion resistance class CRC ²⁾	2	

- 1) Note operating range of proximity sensors
- 2) Corrosion resistance class CRC 2 to Festo standard FN 940070
Moderate corrosion stress. Indoor applications in which condensation can occur. External visible parts with primarily decorative surface requirements which are in direct contact with a normal industrial environment.

Data sheet

Weight [g]					
Size	35	40	50	63	80
HGDD-...-A	309	599	1117	2175	3522
HGDD-...-A-G	370	775	1495	2848	4788

Sectional view

Materials

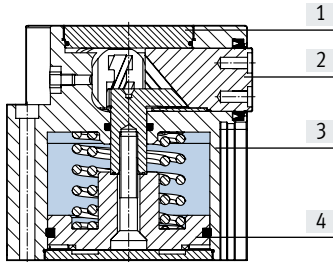

Size	35	40	50	63	80
[1] Cover cap	High-alloy stainless steel				
[2] Gripper jaw	Hardened steel				
[3] Housing	Anodised aluminium				
[4] Piston	Hard-anodised aluminium				
- Seals	Nitrile rubber				
- Note on materials	Free of copper and PTFE		-		
	RoHS-compliant				

Gripping force [N] at 6 bar

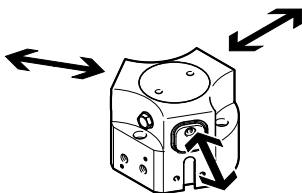

Size	35	40	50	63	80	
Gripping force per gripper jaw						
HGDD-...-A	Opening	122	216	371	582	943
	Closing	112	200	348	553	915
Total gripping force						
HGDD-...-A	Opening	366	648	1113	1746	2829
	Closing	336	600	1044	1659	2745

Characteristic load values at the gripper jaws

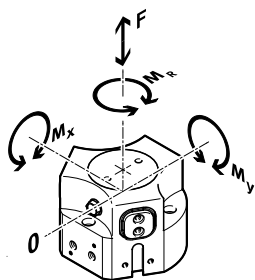

The indicated permissible forces and torques apply to a single gripper jaw. They include the lever arm, additional applied loads due to the workpiece or external gripper fingers and acceleration forces occurring during movement.

The zero coordinate line (gripper jaws point of rotation) must be taken into consideration for the calculation of torques.

Size	35	40	50	63	80	
Max. permissible force F_z	[N]	300	700	1300	2300	3600
Max. permissible torque M_x	[Nm]	12	25	45	70	100
Max. permissible torque M_y	[Nm]	8	18	30	45	65
Max. permissible torque M_r	[Nm]	8	20	30	50	75

Data sheet

Mass moments of inertia [kgcm²]

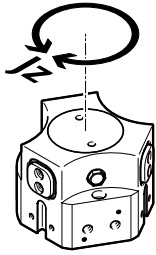

Mass moment of inertia of the three-point gripper in relation to the central axis, without external gripper fingers, without load.

Size	35	40	50	63	80
HGDD-...-A	1.01	3.31	9.65	29	70.22
HGDD-...-A-G	1.37	5.01	15.07	45.05	109

Gripper jaw backlash

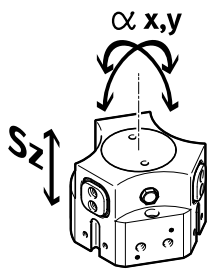

The plain-bearing guide used in the grippers means that there is backlash between the gripper jaws and the guide element. The backlash values listed in the table have been calculated based on the traditional accumulative tolerance method.

Size	35	40	50	63	80
Max. gripper jaw backlash Sz	[mm]	0.05			
Max. gripper jaw angular backlash ax, ay	[°]	0.1			

Opening and closing times [ms] at 6 bar

Without external gripper fingers

With external gripper fingers

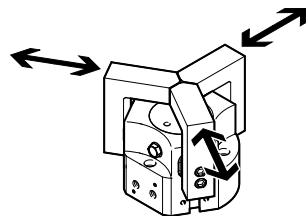
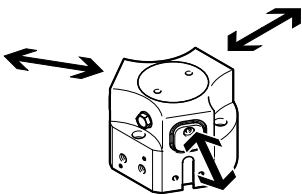

The indicated opening and closing times [ms] were measured at room temperature at an operating pressure of 6 bar with a horizontally mounted gripper without additional gripper fingers. The grippers must be throttled for larger loads [g]. Opening and closing times must then be adjusted accordingly.

Size	35	40	50	63	80	
Without external gripper fingers						
HGDD-...-A	Opening	44	78	93	115	152
	Closing	52	106	128	145	142
HGDD-...-A-G1	Opening	38	70	25	48	72
	Closing	85	211	160	190	246
HGDD-...-A-G2	Opening	81	144	111	135	159
	Closing	42	110	87	68	107
With external gripper fingers (as a function of the load per gripper finger)						
HGDD-...	200 g	52	-	-	-	-
	400 g	74	70	-	-	-
	500 g	83	78	-	-	-
	800 g	105	99	106	-	-
	1000 g	-	111	118	128	-
	1500 g	-	-	145	157	209
	1800 g	-	-	-	172	229
	2000 g	-	-	-	181	241
	2200 g	-	-	-	-	253
	2400 g	-	-	-	-	264

Data sheet

Gripping force F_H per gripper jaw as a function of operating pressure and lever arm x

The gripping forces as a function of the operating pressure and lever arm can be determined from the following graphs.

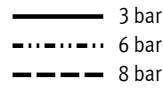
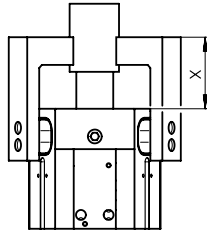

Note
 Engineering software
 Gripper selection
 → www.festo.com

External gripping (closing)

HGDD-35-A

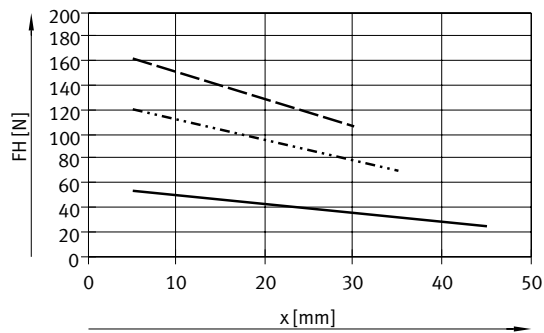

HGDD-40-A

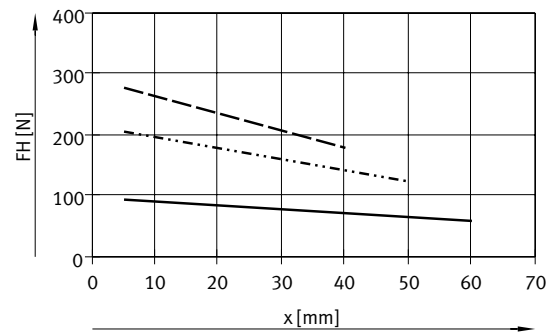

HGDD-50-A

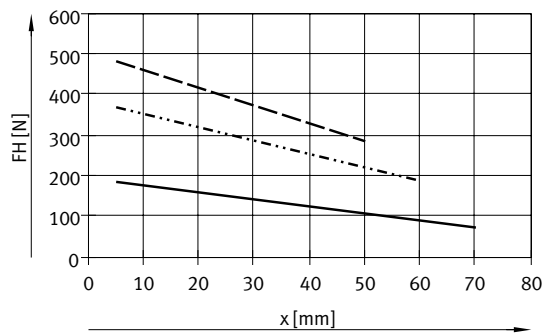

HGDD-63-A

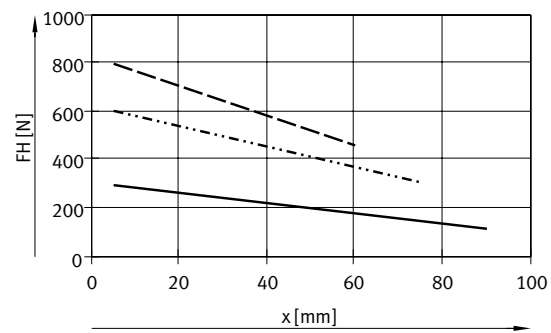

HGDD-80-A

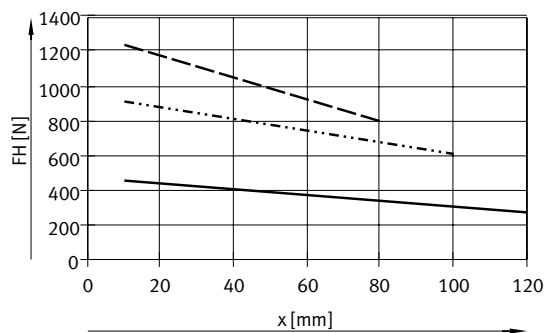

Data sheet

Gripping force F_H per gripper jaw as a function of operating pressure and lever arm x

The gripping forces as a function of the operating pressure and lever arm can be determined from the following graphs.

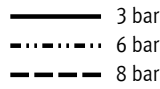
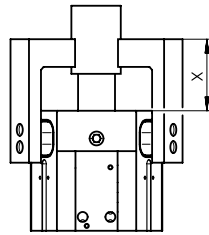

Note
 Engineering software
 Gripper selection
 → www.festo.com

Internal gripping (opening)

HGDD-35-A

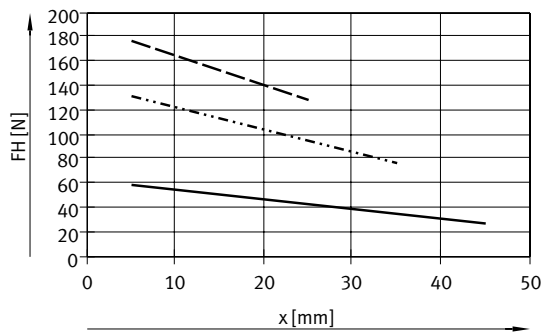

HGDD-40-A

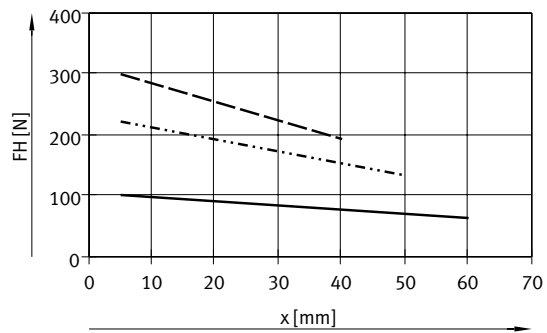

HGDD-50-A

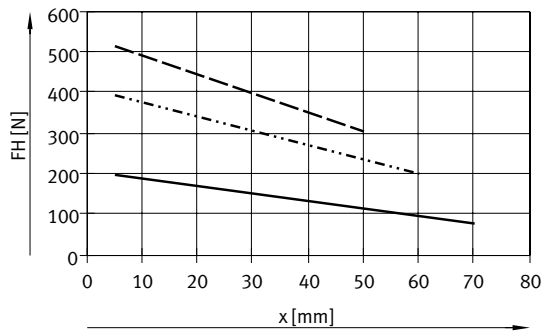

HGDD-63-A

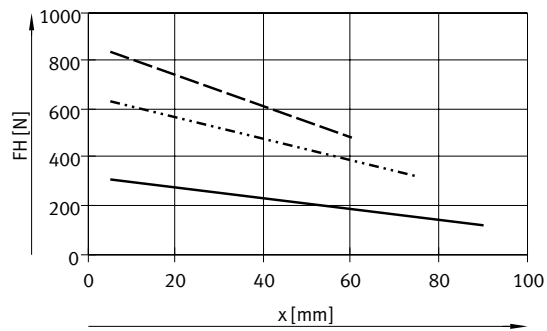

HGDD-80-A

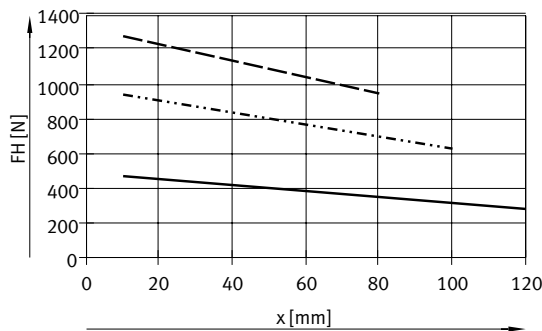

Data sheet

Spring force F_F as a function of size and gripper jaw stroke l per gripper finger

Gripping force retention for HGDD-...-G...

The spring forces F_F as a function of the gripper jaw stroke can be determined from the following graph.

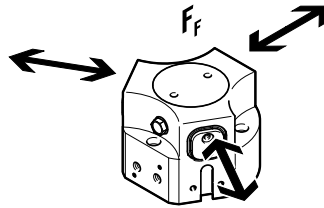

Size 35 ... 50

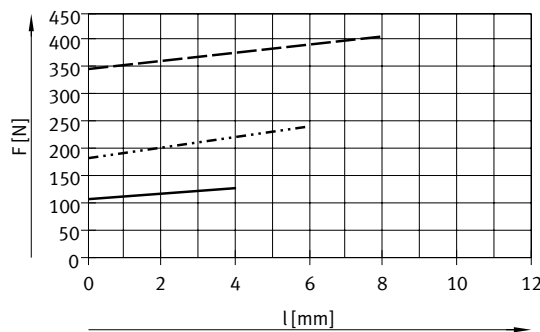

— HGDD-35-A-G
 HGDD-40-A-G
 - - - - HGDD-50-A-G

Size 63 ... 80

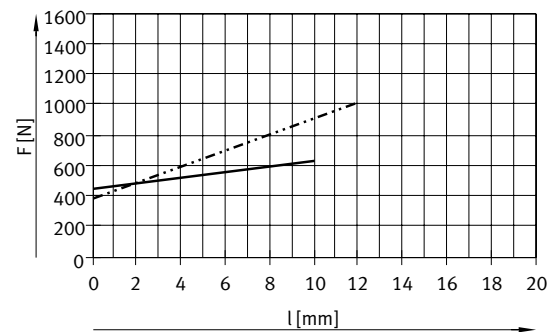

— HGDD-63-A-G
 HGDD-80-A-G

Spring force F_F as a function of size, gripper jaw stroke l and lever arm x per gripper finger

The lever arm x must be taken into consideration when determining the actual spring force F_{Total} .

The formulae for calculating the spring force are provided in the table below.

Gripping force retention	Size	F_{Total} per gripper finger	Gripping force retention	Size	F_{Total} per gripper finger
G1	35	$-0.85 \cdot x + 0.45 \cdot F_F$	G2	35	$-0.6 \cdot x + 0.45 \cdot F_F$
	40	$-0.55 \cdot x + 0.35 \cdot F_F$		40	$-0.55 \cdot x + 0.35 \cdot F_F$
	50	$-2.5 \cdot x + 0.75 \cdot F_F$		50	$-2.5 \cdot x + 0.6 \cdot F_F$
	63	$-0.2 \cdot x + 0.4 \cdot F_F$		63	$-1.0 \cdot x + 0.4 \cdot F_F$
	80	$-1.5 \cdot x + 0.35 \cdot F_F$		80	$-4.0 \cdot x + 0.85 \cdot F_F$

Determining the actual gripping forces F_{Gr} per gripper finger for HGDD-...-G1 and HGDD-...-G2 as a function of application

The three-point grippers with integrated spring type HGDD-...-G1 (opening gripping force retention) and HGDD-...-G2 (closing gripping force retention) can be used as

- single-acting grippers
- grippers with supplementary gripping force and
- grippers with gripping force retention

In order to calculate the available gripping forces F_{Gr} (per gripper finger), the data for gripping force F_H and spring force F_{Total} must be combined accordingly.

Application forces per gripper finger

Single-acting

Supplementary gripping force

Gripping force retention

- Gripping with spring force:

$$F_{Gr} = F_{\text{Total}}$$

- Gripping with pressure force:

$$F_{Gr} = F_H - F_{\text{Total}}$$

- Gripping with pressure and spring force:

$$F_{Gr} = F_H + F_{\text{Total}}$$

- Gripping with spring force:

$$F_{Gr} = F_{\text{Total}}$$

Data sheet

Dimensions

Download CAD data → www.festo.com

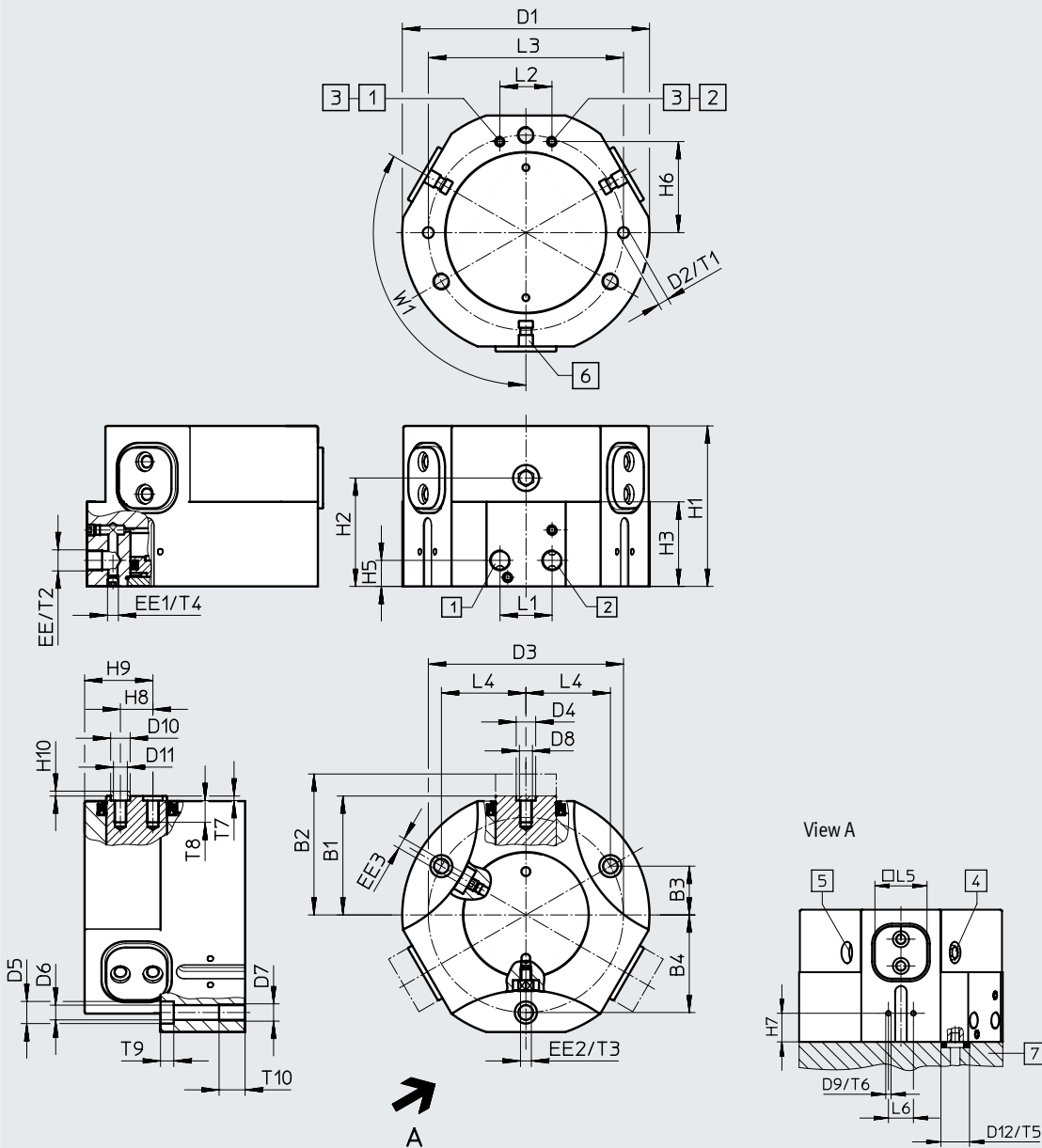

- [1] Supply port, opening
 - [2] Supply port, closing
 - [3] Alternative air supply port (supplied sealed)
 - [4] Exhaust hole (filter integrated)
 - [5] Lubrication nipple (supplied sealed)
 - [6] Slot for proximity sensor
 - [7] O-ring for three-point gripper
- HGDD-35: $\varnothing 3 \times 1.5$
 HGDD-40 ... 80: $\varnothing 5 \times 1.5$

Data sheet

Size	B1	B2	B3	B4	D1	D2	D3	D4	D5	D6	D7	D8	D9
[mm]	±0.5	±0.5			∅ ±0.1	∅ H8	∅ ±0.1	∅ H8	∅ H13	∅ H13			
35	28	32	11	22	58	3	44	5	5.9	3.3	M4	M3	M3
40	36	42	14	28	74	4	56	7	9.4	5.1	M6	M4	M3
50	44.5	52.5	17.5	35	93	5	70	9	10.2	6.8	M8	M6	M3
63	55	65	22.5	45	114	5	90	9	10.2	6.8	M8	M6	M3
80	68	80	28	56	139	6	112	9	13.5	8.4	M10	M6	M3

Size	D10	D11	D12	EE	EE1	EE2	EE3	H1		H2	
								∅ H7	∅ +0.2		
35	5	3.2	6	M5	M3	M3	M3	41	51	29	39
40	7	5.3	8	M5	M5	M3	M3	48.5	66	34.5	52
50	9	6.4	8	G1/8	M5	M5	M5	58.5	83.5	40.4	65.4
63	9	6.4	8	G1/8	M5	M5	M5	74	104	50	80
80	9	6.4	8	G1/8	M5	G1/8	M5	83.5	120.5	55.5	92.5

Size	H3		H5	H6	H7		H8 ¹⁾	H9	H10	L1	L2	L3	L4
	-G -0.2	-G -0.2			±0.1	±0.1							
35	23	33	9	18.5	7	17	7	15.5	1.2	12	15	45	19.05
40	27.5	45	9	25	10	27.5	10	19	1.4	12	18	56	24.25
50	32.5	57.5	12	32	12.5	37.5	12	24.1	1.9	24	18	70	30.31
63	39	69	12	42	16	46	15	31.5	1.9	24	24	90	38.97
80	43	80	12	53	21	58	18	37	1.9	30	30	112	48.5

Size	L5	L6	T1	T2	T3	T4	T5	T6	T7	T8	T9	T10	W1
[mm]	-0.02	±0.1	min.	min.	min.	min.	+0.1	min.	+0.1	min.	+0.2	min.	
35	14	12	5	5	3	3	1.2	4	1.3	5	3.2	8	120°
40	18	12	6	6	3	5	1.2	5	1.6	6	5	10	120°
50	22	12	8	7	6	5	1.2	5	2.1	10	6.1	12	120°
63	28	14	8	7	6	5	1.2	5	2.1	10	6.1	12	120°
80	32	14	10	8	10	5	1.2	5	2.1	10	8	15	120°

1) Tolerance for centring hole ±0.02 mm
Tolerance for thread ±0.1 mm

Size	Double-acting		Single-acting or with gripping force retention			
	Without compression spring		Opening		Closing	
[mm]	Part no.	Type	Part no.	Type	Part no.	Type
35	1163037	HGDD-35-A	1163038	HGDD-35-A-G1	1163039	HGDD-35-A-G2
40	1163040	HGDD-40-A	1163041	HGDD-40-A-G1	1163042	HGDD-40-A-G2
50	1163043	HGDD-50-A	1163044	HGDD-50-A-G1	1163045	HGDD-50-A-G2
63	1163046	HGDD-63-A	1163047	HGDD-63-A-G1	1163048	HGDD-63-A-G2
80	1163049	HGDD-80-A	1163050	HGDD-80-A-G1	1163051	HGDD-80-A-G2

Three-point grippers HGDD, sealed

Accessories

Adapter kit
DHAA, HAPG

Material:
Wrought aluminium alloy
Free of copper and PTFE
RoHS-compliant



Note

The kit includes the individual mounting interface as well as the necessary mounting material.

Permissible drive/gripper combinations with adapter kit

Download CAD data → www.festo.com

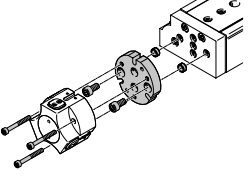
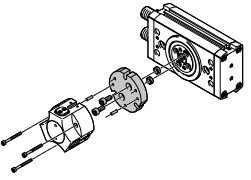
Combination	Actuator Size	Grippers Size	Adapter kit			
			CRC ¹⁾	Part no.	Type	
	DGSL	HGDD	DHAA			
	16, 20, 25	35	2	2371422	DHAA-G-G3-20-B13-35	
	20, 25	40		2373773	DHAA-G-H2-16-B13-40	
	25	50		2377625	DHAA-G-H2-20-B13-50	
	DGSL	HGDD-G1/G2	DHAA, HAPG			
	16, 20, 25	35	2	542436	HAPG-94	
	20, 25	40		542437	HAPG-95	
	25	50		2378415	DHAA-G-H2-20-B13G-50	
		DRRD	HGDD	DHAA		
		20	35	2	2075498	DHAA-G-Q11-20-B13-35
25		35	1718041		DHAA-G-Q11-25-B13-35	
25		40	1718564		DHAA-G-Q11-25-B13-40	
32		40	2077119		DHAA-G-Q11-32-B13-40	
32		50	2078975		DHAA-G-Q11-32-B13-50	
35		50	2079171		DHAA-G-Q11-35-B13-50	
35, 40		63	2079579		DHAA-G-Q11-3 5/40-B13-63	
DRRD		HGDD-G1/G2	DHAA			
20		35	2	2837144	DHAA-G-Q11-20-B13G-35	
25		35		2837169	DHAA-G-Q11-25-B13G-35	
25		40		2837182	DHAA-G-Q11-25-B13G-40	
32		40		2837254	DHAA-G-Q11-32-B13G-40	
32		50		2837269	DHAA-G-Q11-32-B13G-50	
35		50		2837283	DHAA-G-Q11-35-B13G-50	
35, 40		63		2837337	DHAA-G-Q11-3 5/40-B13G-63	

1) Corrosion resistance class CRC 2 to Festo standard FN 940070

Moderate corrosion stress. Indoor applications in which condensation can occur. External visible parts with primarily decorative surface requirements which are in direct contact with a normal industrial environment.

Accessories

Adapter kit DHAA/HAPG

Material:
Wrought aluminium alloy
Free of copper and PTFE
RoHS-compliant



Note

The kit includes the individual mounting interface as well as the necessary mounting material.

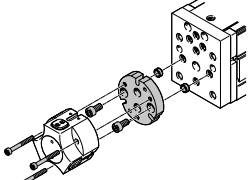
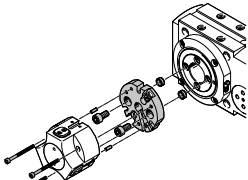
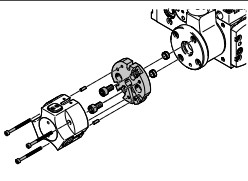
Permissible drive/gripper combinations with adapter kit				Download CAD data → www.festo.com		
Combination	Actuator Size	Grippers Size	Adapter kit			
			CRC ¹⁾	Part no.	Type	
	EGSL	HGDD	DHAA			
	45, 55, 75	35	2	2371422	DHAA-G-G3-20-B13-35	
	75	40		2373773	DHAA-G-H2-16-B13-40	
	75	50		2377625	DHAA-G-H2-20-B13-50	
	EGSL	HGDD-G1/G2	DHAA, HAPG			
	45, 55, 75	35	2	542436	HAPG-94	
	75	40		542437	HAPG-95	
75	50	2378415		DHAA-G-H2-20-B13G-50		
	ERMB	HGDD	DHAA			
	20, 25, 32	35	2	2376297	DHAA-G-Q5-20-B13-35	
	25, 32	40		2376728	DHAA-G-Q5-25-B13-40	
	32	50		2377625	DHAA-G-H2-20-B13-50	
	ERMB	HGDD-G1/G2	DHAA, HAPG			
	20, 25, 32	35	2	542441	HAPG-SD2-34	
	25, 32	40		542442	HAPG-SD2-35	
32	50	2378415		DHAA-G-H2-20-B13G-50		
	EHMB	HGDD	DHAA			
	20	35	2	2376297	DHAA-G-Q5-20-B13-35	
	20	40		2376728	DHAA-G-Q5-25-B13-40	
	20	50		2377625	DHAA-G-H2-20-B13-50	
	EHMB	HGDD-G1/G2	DHAA, HAPG			
	20	35	2	542441	HAPG-SD2-34	
	20	40		542442	HAPG-SD2-35	
20	50	2378415		DHAA-G-H2-20-B13G-50		

1) Corrosion resistance class CRC 2 to Festo standard FN 940070

Moderate corrosion stress. Indoor applications in which condensation can occur. External visible parts with primarily decorative surface requirements which are in direct contact with a normal industrial environment.

Accessories

Gripper jaw blank BUB-HGDD

(3 included in the scope of delivery)

Material:

Wrought aluminium alloy

Free of copper and PTFE

RoHS-compliant

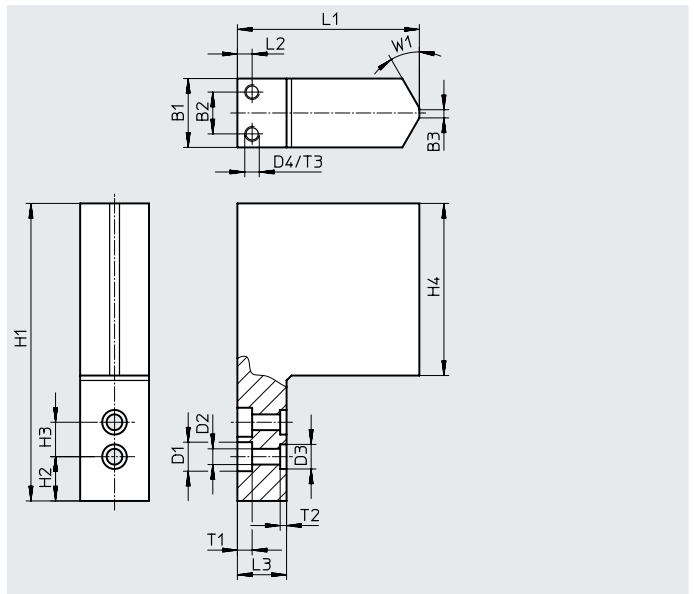
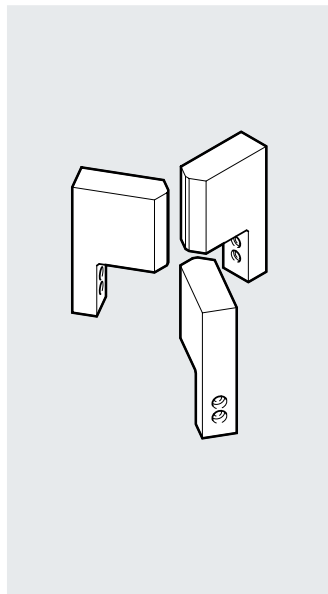

Dimensions and ordering data

For size	B1	B2	B3	D1 ∅	D2 ∅	D3 ∅	D4
[mm]	±0.05			H13	H13	H8	
35	14	8.5	2	5.9	3.2	5	M3
40	20	14	2	7.4	4.3	7	M3
50	29	23	2	10.4	6.4	9	M3
63	32	26	2	10.4	6.4	9	M3
80	35	26	2	10.4	6.4	9	M3

For size	H1	H2	H3 ¹⁾	H4	L1	L2	L3
[mm]	±0.05	±0.02			±0.05		
35	60.5	9	7	35	37	3	10
40	77	7	10	50	45	5	10
50	96	11	12	60	55	6	12
63	121	13.5	15	75	64	6	12
80	153.5	15.5	18	100	79.4	10	15

For size	T1	T2	T3	W1	Weight per blank [g]	Part no.	Type
[mm]		+0.1					
35	3 ^{+0.2}	1.3	5	30°	57	1180955	BUB-HGDD-35
40	4 ^{+0.2}	1.6	5	30°	131	1180956	BUB-HGDD-40
50	6.1 ^{+0.1}	2.1	5	30°	276	1180957	BUB-HGDD-50
63	6.1 ^{+0.1}	2.1	5	30°	440	1180958	BUB-HGDD-63
80	6.1 ^{+0.1}	2.1	5	30°	793	1180959	BUB-HGDD-80

1) ±0.02 and ±0.01 apply to the centring hole D3
±0.1 applies to the through-holes D1 and D2

Accessories

Sensor bracket DASI

(1 included in the scope of delivery)

Material:

Wrought aluminium alloy

RoHS-compliant

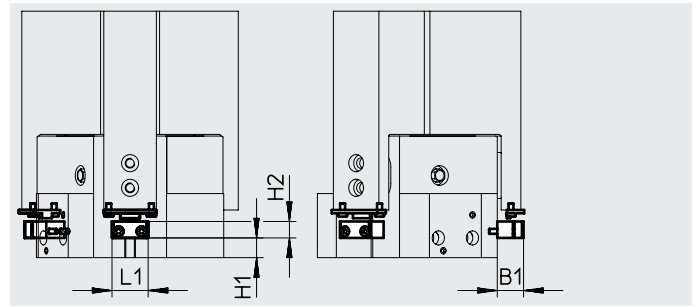
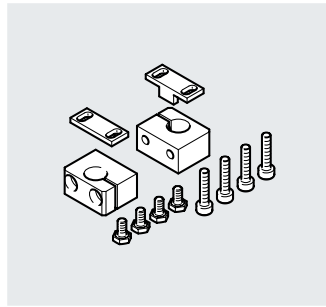

Dimensions and ordering data								
For size	B1	H1		H2	L1	Weight	Part no.	Type
[mm]			-G			[g]		
35	13	3	13	8	21	20	1435236	DASI-B13-35-S3
40	16	6	23.5	10	20	27	1435232	DASI-B13-40-S8
50	16	8.5	33.5	10	20	30	1435233	DASI-B13-50-S8
63	16	10	36	10	22	35	1435234	DASI-B13-63-S8
80	22	10	47	15	22	45	1435235	DASI-B13-80-S8

Ordering data						
	For size [mm]	Comment	Weight [g]	Part no.	Type	PU ¹⁾
Centring sleeve ZBH Data sheets → Internet: zbh						
	35	For centring the gripper jaw blanks/gripper fingers on the gripper jaws	1	8146543	ZBH-5-B	10
	40		1	8146544	ZBH-7-B	
	50, 63, 80		1	8137184	ZBH-9-B	
Blanking plug B Data sheets → Internet: blanking plug						
	35, 40	For sealing the compressed air supply ports	1	174308	B-M5-B	10
	50, 63, 80		5	3568	B-1/8	

1) Packaging unit

Ordering data – Proximity sensor for T-slot, magneto-resistive Data sheets → Internet: smt						
	Type of mounting	Electrical connection, outlet direction of connection	Switching output	Cable length [m]	Part no.	Type
N/O contact						
	Inserted in the slot lengthwise	Cable, 3-wire, lateral	PNP	2.5	547859	SMT-8G-PS-24V-E-2.5Q-OE
		Plug M8x1, 3-pin, lateral		0.3	547860	SMT-8G-PS-24V-E-0.3Q-M8D
		Cable, 3-wire, lateral	NPN	2.5	8065028	SMT-8G-NS-24V-E-2.5Q-OE
		Plug M8x1, 3-pin, lateral		0.3	8065027	SMT-8G-NS-24V-E-0.3Q-M8D

Ordering data – Connecting cables Data sheets → Internet: nebu						
	Electrical connection, left	Electrical connection, right	Cable length [m]	Part no.	Type	
	Straight socket, M8x1, 3-pin	Cable, open end, 3-wire	2.5	541333	NEBU-M8G3-K-2.5-LE3	
			5	541334	NEBU-M8G3-K-5-LE3	
	Angled socket, M8x1, 3-pin	Cable, open end, 3-wire	2.5	541338	NEBU-M8W3-K-2.5-LE3	
			5	541341	NEBU-M8W3-K-5-LE3	

Accessories

Proximity sensor for size 35

Ordering data – Proximity sensor 3 mm (round design), inductive Data sheets → Internet: sieh



	Electrical connection	LED	Switching output	Cable length [m]	Part no.	Type
N/O contact						
	Cable, 3-wire	■	PNP	2.5	538264	SIEH-3B-PS-K-L
	Plug M8x1, 3-pin	■		-	538263	SIEH-3B-PS-S-L

Proximity sensor for size 40 ... 80

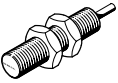
Ordering data – Proximity sensor M8 (round design), inductive Data sheets → Internet: sien

	Electrical connection	LED	Switching output	Cable length [m]	Part no.	Type
N/O contact						
	Cable, 3-wire	■	PNP	2.5	150386	SIEN-M8B-PS-K-L
	Plug M8x1, 3-pin	■		-	150387	SIEN-M8B-PS-S-L

Ordering data – Connecting cables Data sheets → Internet: nebu

	Electrical connection, left	Electrical connection, right	Cable length [m]	Part no.	Type
	Straight socket, M8x1, 3-pin	Cable, open end, 3-wire	2.5	541333	NEBU-M8G3-K-2.5-LE3
			5	541334	NEBU-M8G3-K-5-LE3
	Angled socket, M8x1, 3-pin	Cable, open end, 3-wire	2.5	541338	NEBU-M8W3-K-2.5-LE3
			5	541341	NEBU-M8W3-K-5-LE3